

**New Rubber Seals**  
Easier assembly for a quicker install!



# DEF-Trac®

Flexible Piping by Omegaflex®

DEF-Trac® addresses the emerging needs of the DEF supply industry. Unaffected by corrosive effects of DEF, DEF-Trac is manufactured from corrugated 316L stainless steel, and is supplied in long coils to streamline the installation of the distribution piping from the storage tank to the dispensing pumps.

**Simplified Rubber Seals** - The implementation of rubber seals eliminates time-consuming heat shrink sleeves, simplifying the installation and reducing install time.

Combined with simple mechanical fittings, the entire system can be installed, without any intermediate joints, by one person using standard hand tools. DEF-Trac is designed with a highly insulated jacket and can be supplied with integrated heat tracing. Omegaflex has a well-earned reputation as a leader in flexible piping technology and has developed a number of unique corrugated tubing products specifically for the distribution of liquid and gaseous fuels including DEF-Trac.

- 316L Highly flexible stainless steel tubing
- Stainless steel fittings - field attachable
- Self flaring – metal to metal sealing
- Available with or without insulation or heat trace
- No special tools required for assembly
- Fluid components meet ISO 22241-3 standard
- Minimum media maintain temperature = 30°F
- Will maintain minimum media temperature when ambient temperature is down to -20° F
- Operating voltage: 120 VAC only
- One thermon low-temp self-regulating heater BSX
- Maximum circuit length will be 200 feet
- 200 foot line will draw approx. 8.0A nominal operating current

With 120VAC power continuously applied (no temperature control device in the circuit) on a 85°F ambient day, the steady state (no flow) equilibrium temperature of the internal hose will be approximately 115°F.

The Thermon BSX heater cable has a Class 1 Div II T6 rating as issued by Factory Mutual (FM). Use only appropriate Thermon cable termination kits [specifically the Thermon PETK-1D Power Termination kit or the Thermon SCTK-1D Splice kit.]

### DEF-Trac Flexible Piping Specifications

Size: Nominal ID	Reel Length	Description	Max Operating Pressure (psig)	Minimum Bend Radius (inches)	Nominal OD
1"	200 ft	DEF-Trac Flexible Piping: Un-insulated without heat trace	50	7	1.41
1½"			50	12	1.93
2"			50	14	2.51
1"	200 ft	DEF-Trac Flexible Piping: Insulated with or without heat trace	50	18	2.65
1½"			50	30	3.15
2"			50	35	3.50

# DEF-Trac<sup>®</sup>

## Specification Sheet

with simplified Rubber Seals

### Insulated End Configuration

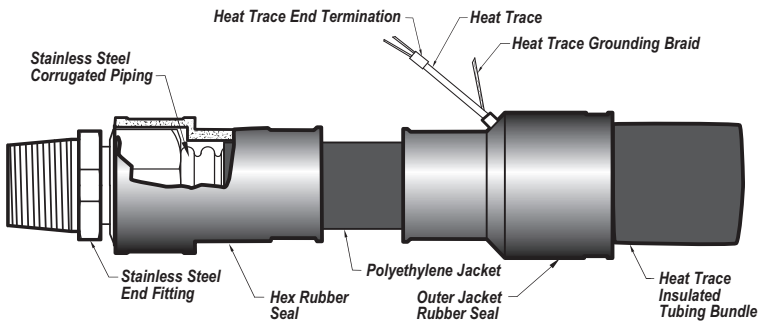

### Un-Insulated End Configuration

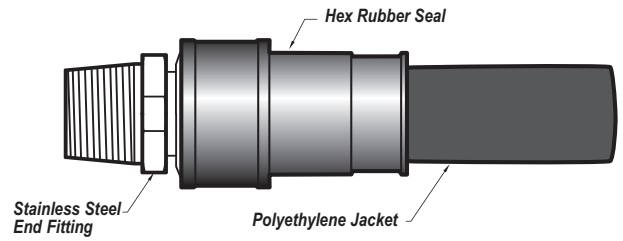

**CAUTION NOTE:** MANDATORY GFI EPD CIRCUIT BREAKER PER NEC ARTICLE 427-22, ALL HEAT TRACING CIRCUITS MUST HAVE GFI-EQUIPMENT PROTECTION ON THE CIRCUIT. IN THIS SYSTEM, THE HEATER CABLE MUST BE POWERED FROM AN EPD (30MA GFI TRIP) TYPE CIRCUIT BREAKER.

**NOTE:** MAXIMUM CIRCUIT LENGTH IS 200 ft.

### DEF-Trac<sup>®</sup> End Fittings

Description	Size	Part No.
SS Field Attachable - 1" NPT	1"	DF-FST-16
SS Field Attachable - 1-1/2" NPT	1½"	DF-FST-24
SS Field Attachable - 2" NPT	2"	DF-FST-32

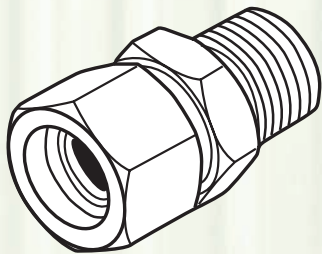

1" SS Fitting

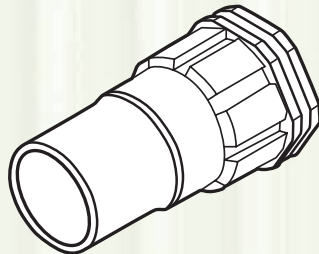

Bulkhead Entry Fitting

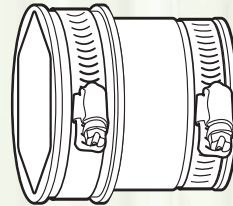

NEW Hex Rubber Seal

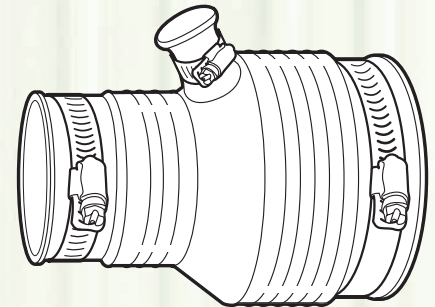

NEW Outer Jacket Rubber Seal

### DEF-Trac<sup>®</sup> Accessories

Description	Size	Part No.
1" & 1½" Bundle Bulkhead Entry Fitting	1" & 1½"	DF-FAK-9L
2" Bundle Bulkhead Entry Fitting	2"	DF-FAK-9LX
DEF-Trac Boot Pipe / Nut	All	DF-BTNP-xxKT*
DEF-Trac Boot Pipe / Bundle	All	DF-BTHP-xxKT*
DEF-Trac Boot Pipe / Ducting	All	DF-BTHD-xxKT*
4" Heavy Duty Corrugated Ducting	4"	UGF-CP-4
Tubing Cutter	All	UGF-TC-152
Spare Wheel for Tubing Cutter	All	UGF-E-5272
Leak Check Solution	All	UGF-LCS

\*xx replaced by 16, 24, 32

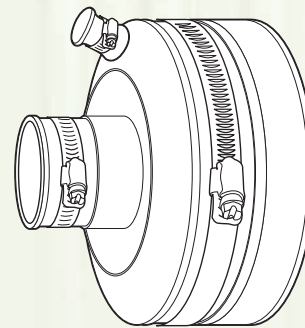

NEW 4" Rubber Seal

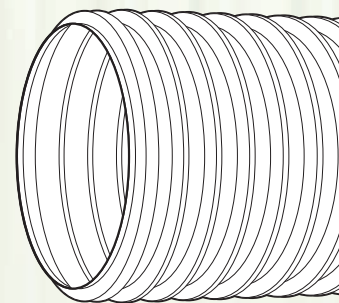

NEW 4" Ducting

See the DEF-Trac price sheet for a complete list of DEF-Trac accessories, including Thermon heat trace accessories.

For additional information, please contact your manufacturer's representative or visit our website:

[WWW.DOUBLETRAC.NET](http://WWW.DOUBLETRAC.NET)

OMEGA FLEX, INC.

451 Creamery Way, Exton PA 19341  
1-800-671-8622 Fax: 610-524-7282



ISO 9001  
OM-ISA Global

